

■ PRODUCT CHARACTERISTICS

VDSS	650V
$R_{DS(on)max}(@V_{GS} = 10\text{ V})$	0.86Ω
Qg@type	44nC
ID	10A

Symbol

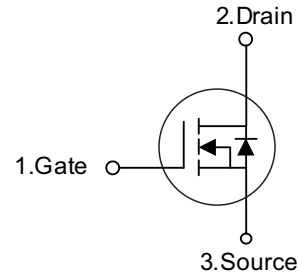

■ APPLICATIONS

- High frequency switching mode power supply
- Electronic ballast
- UPS

■ FEATURES

- * $R_{DS(ON)} = 0.86\Omega @ V_{GS} = 10\text{ V}$
- * Ultra low gate charge
- * Fast switching capability
- * Avalanche energy tested
- * Improved dv/dt capability, high ruggedness

■ ORDER INFORMATION

Order codes		Package	Packing
Halogen-Free	Halogen		
N/A	SMF10N65	TO-220F	50 pieces/Tube
N/A	SMP10N65	TO-220	50 pieces/Tube

■ ABSOLUTE MAXIMUM RATINGS ($T_C = 25^\circ\text{C}$ unless otherwise specified)

PARAMETER	SYMBOL	RATINGS	UNIT
Drain-Source Voltage	V_{DSS}	650	V
Gate-Source Voltage	V_{GSS}	± 30	V
Avalanche Current (Note 2)	I_{AR}	10	A
Drain Current	Continuous	I_D	10
	Pulsed (Note 2)	I_{DM}	38
Avalanche Energy	Single Pulsed (Note 3)	E_{AS}	700
	Repetitive (Note 2)	E_{AR}	15.6
Peak Diode Recovery dv/dt (Note 4)	dv/dt	4.5	V/ns
Power Dissipation	TO-220	P_D	156
	TO-220F		50
Junction Temperature	T_J	+150	°C
Operating Temperature	T_{OPR}	-55 ~ +150	°C
Storage Temperature	T_{STG}	-55 ~ +150	°C

Notes: 1. Absolute maximum ratings are those values beyond which the device could be permanently damaged.

Absolute maximum ratings are stress ratings only and functional device operation is not implied.

2. Repetitive Rating: Pulse width limited by maximum junction temperature

3. $L = 14.2\text{mH}$, $I_{AS} = 10\text{A}$, $V_{DD} = 50\text{V}$, $R_G = 25\ \Omega$ Starting $T_J = 25^\circ\text{C}$

4. $I_{SD} \leq 9.5\text{A}$, $di/dt \leq 200\text{A}/\mu\text{s}$, $V_{DD} \leq BV_{DSS}$, Starting $T_J = 25^\circ\text{C}$

■ THERMAL DATA

PARAMETER	SYMBOL	RATINGS	UNIT
Junction to Ambient	θ_{JA}	62.5	°C/W
Junction to Case	TO-220	θ_{JC}	0.92
	TO-220F		3.29

■ ELECTRICAL CHARACTERISTICS (T_C = 25°C, unless otherwise specified)

PARAMETER	SYMBOL	TEST CONDITIONS	MIN	TYP	MAX	UNIT
OFF CHARACTERISTICS						
Drain-Source Breakdown Voltage	BV _{DSS}	V _{GS} = 0V, I _D = 250μA	650			V
Drain-Source Leakage Current	I _{DSS}	V _{DS} = 650V, V _{GS} = 0V			1	μA
Gate-Source Leakage Current	Forward	I _{GSS} V _{GS} = 30 V, V _{DS} = 0 V			100	nA
	Reverse		V _{GS} = -30 V, V _{DS} = 0 V			-100
Breakdown Voltage Temperature Coefficient	ΔBV _{DSS} /ΔT _J	I _D = 250 μA, Referenced to 25°C		0.7		V/°C
ON CHARACTERISTICS						
Gate Threshold Voltage	V _{GS(TH)}	V _{DS} = V _{GS} , I _D = 250μA	2.0		4.0	V
Static Drain-Source On-State Resistance	R _{DSON}	V _{GS} = 10V, I _D = 5.0A		0.72	0.86	Ω
DYNAMIC CHARACTERISTICS						
Input Capacitance	C _{ISS}	V _{DS} =25V, V _{GS} =0V, f=1.0 MHz		1570	2040	pF
Output Capacitance	C _{OSS}			166	215	pF
Reverse Transfer Capacitance	C _{RSS}			18	24	pF
SWITCHING CHARACTERISTICS						
Turn-On Delay Time	t _{D(ON)}	V _{DD} =325V, I _D =10A, R _G =25Ω (Note 1, 2)		23	55	ns
Turn-On Rise Time	t _R			69	150	ns
Turn-Off Delay Time	t _{D(OFF)}			144	300	ns
Turn-Off Fall Time	t _F			77	165	ns
Total Gate Charge	Q _G	V _{DS} =520V, I _D =10A, V _{GS} =10 V (Note 1, 2)		44	57	nC
Gate-Source Charge	Q _{GS}			6.7		nC
Gate-Drain Charge	Q _{GD}			18.5		nC
DRAIN-SOURCE DIODE CHARACTERISTICS AND MAXIMUM RATINGS						
Drain-Source Diode Forward Voltage	V _{SD}	V _{GS} = 0 V, I _S =10A			1.4	V
Maximum Continuous Drain-Source Diode Forward Current	I _S				10	A
Maximum Pulsed Drain-Source Diode Forward Current	I _{SM}				38	A
Reverse Recovery Time	t _{rr}	V _{GS} = 0 V, I _S = 10A,		420		ns
Reverse Recovery Charge	Q _{RR}	dI _F / dt = 100 A/μs (Note 1)		4.2		μC

Notes: 1. Pulse Test : Pulse width ≤300μs, Duty cycle ≤2%
2. Essentially independent of operating temperature

■ TEST CIRCUITS AND WAVEFORMS

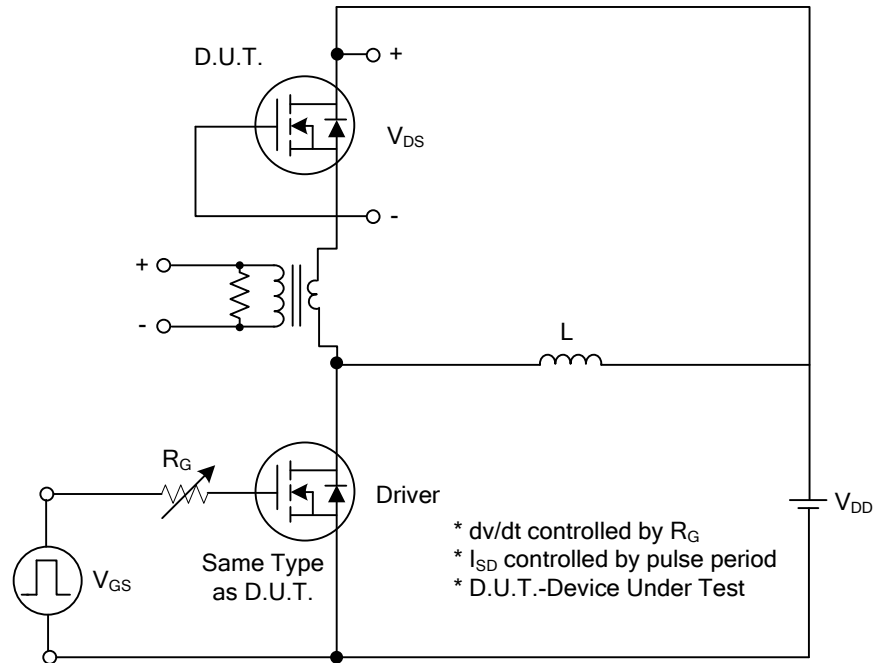

Peak Diode Recovery dv/dt Test Circuit

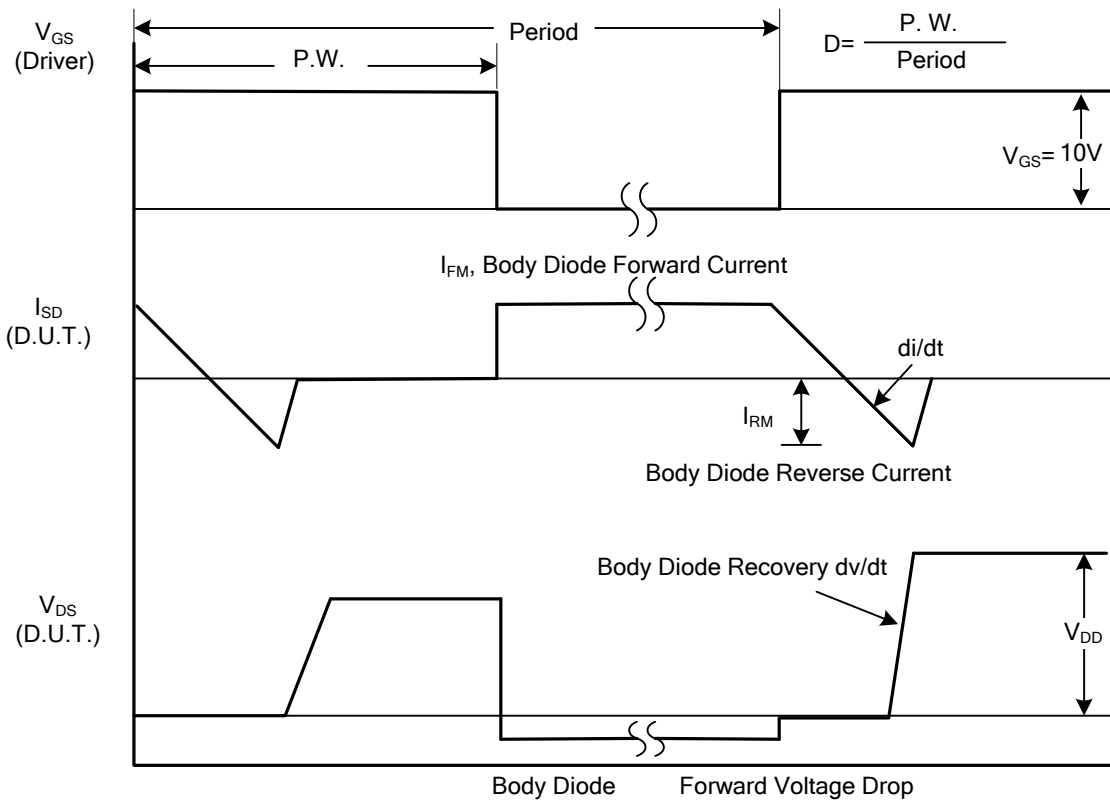

Peak Diode Recovery dv/dt Waveforms

■ TEST CIRCUITS AND WAVEFORMS(Cont.)

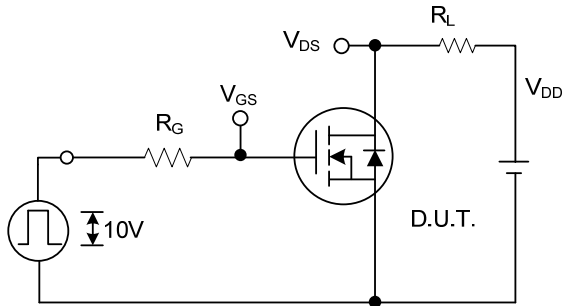

Switching Test Circuit

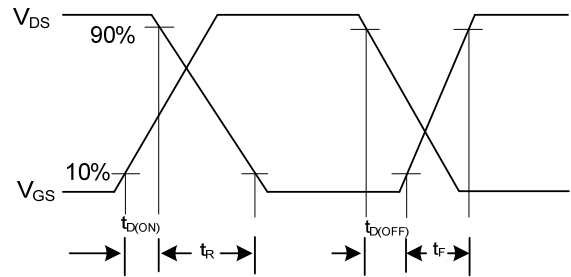

Switching Waveforms

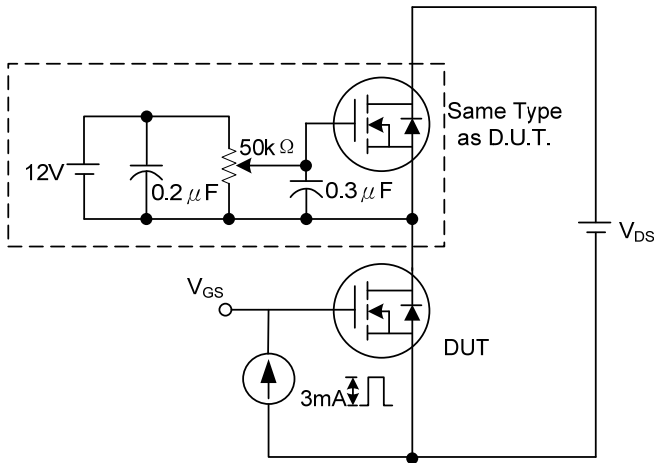

Gate Charge Test Circuit

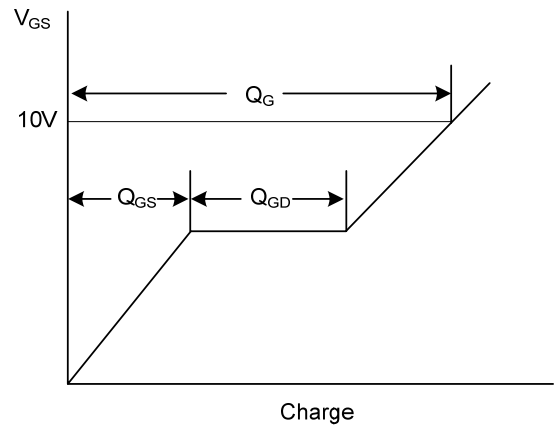

Gate Charge Waveform

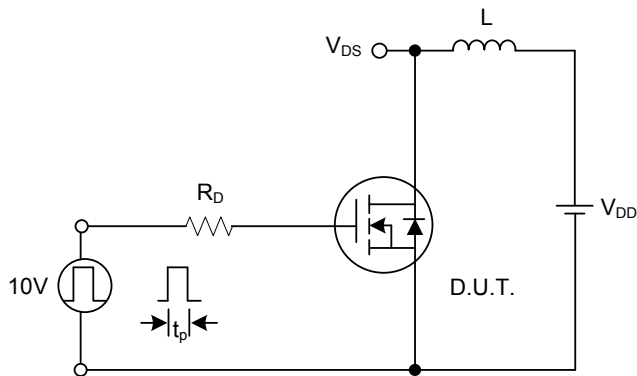

Unclamped Inductive Switching Test Circuit

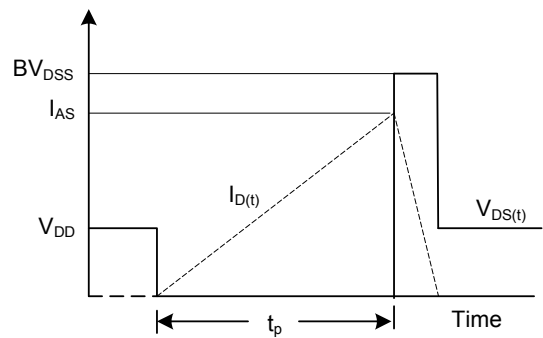

Unclamped Inductive Switching Waveforms

■ TYPICAL CHARACTERISTICS

On-Region Characteristics

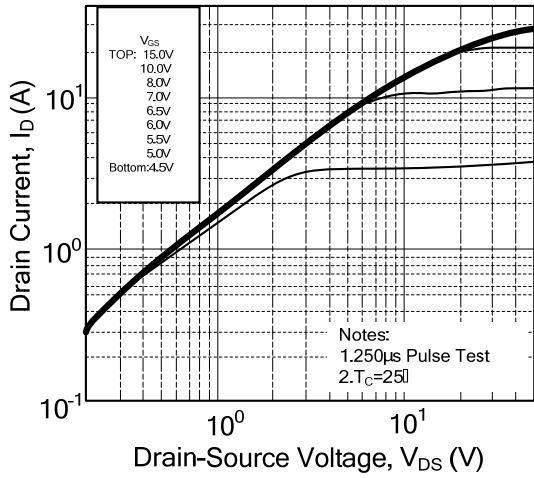

Transfer Characteristics

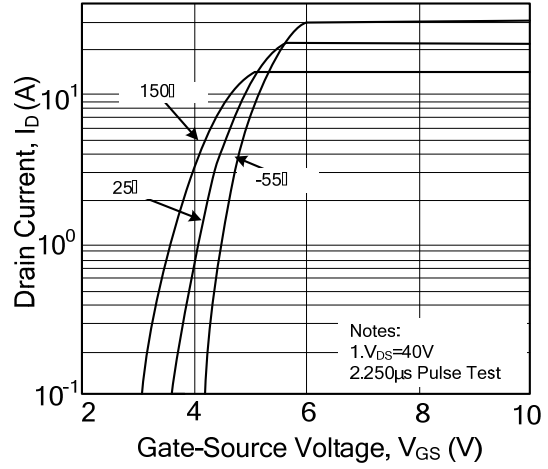

On-Resistance Variation vs. Drain Current and Gate Voltage

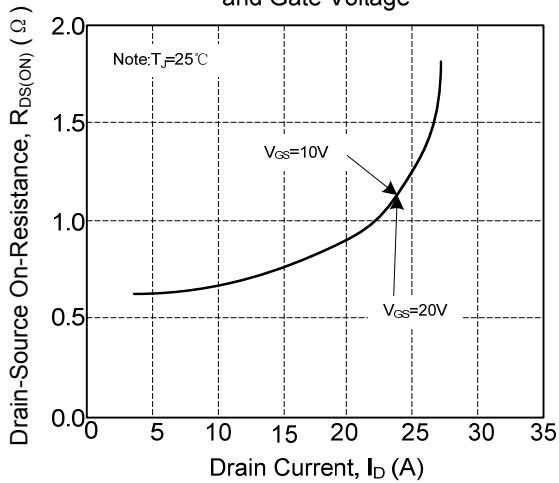

Body Diode Forward Voltage Variation with Source Current and Temperature

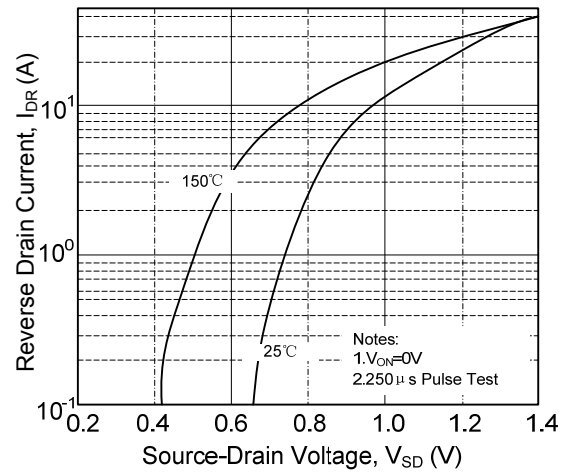

Capacitance Characteristics

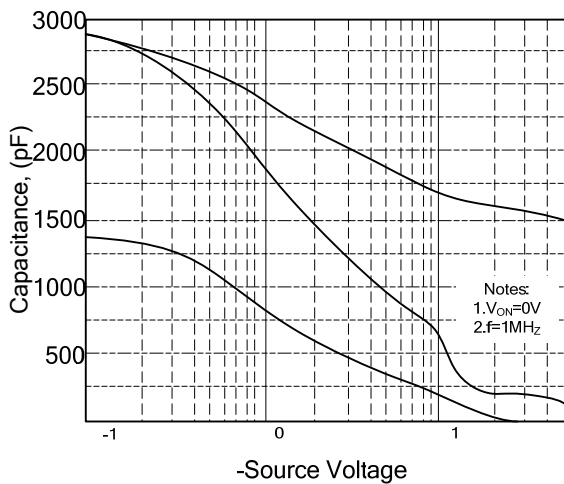

Gate Charge Characteristics

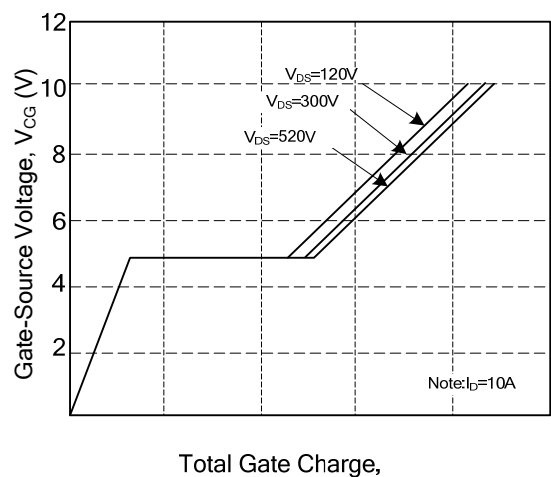

■ TYPICAL CHARACTERISTICS(Cont.)

Breakdown Voltage Variation vs. Temperature

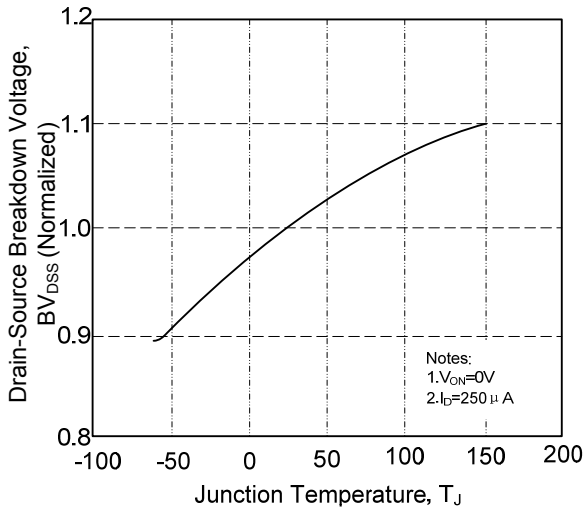

On-Resistance Variation vs. Temperature

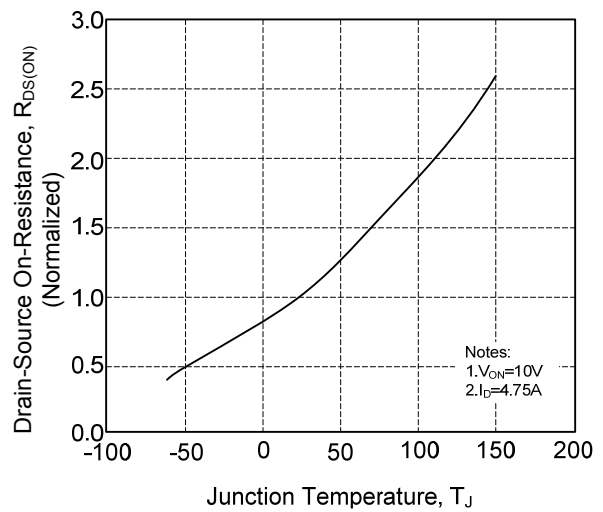

Maximum Safe Operating Area

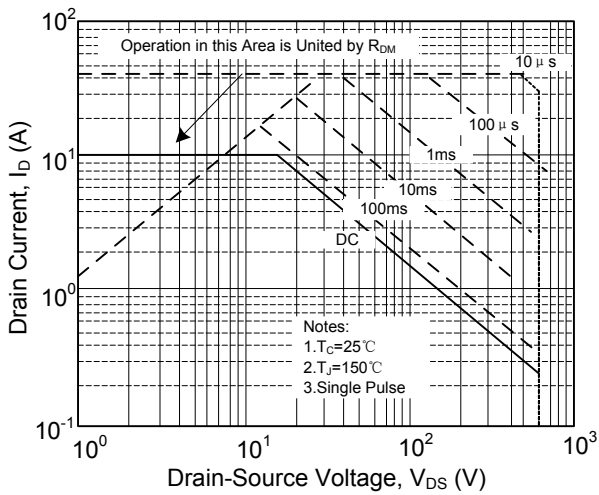

Maximum Drain Current vs. Case Temperature

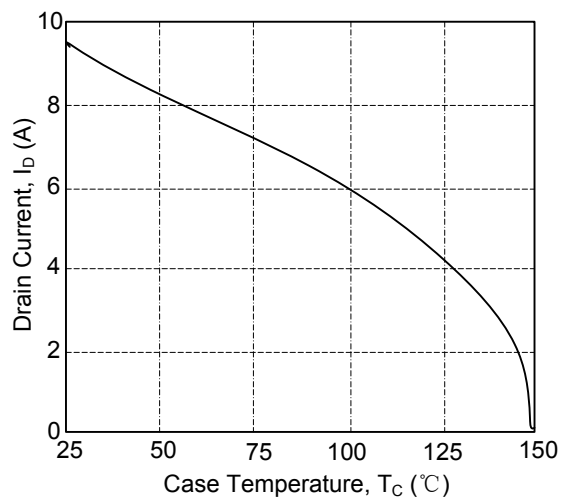

Transient Thermal Response Curve

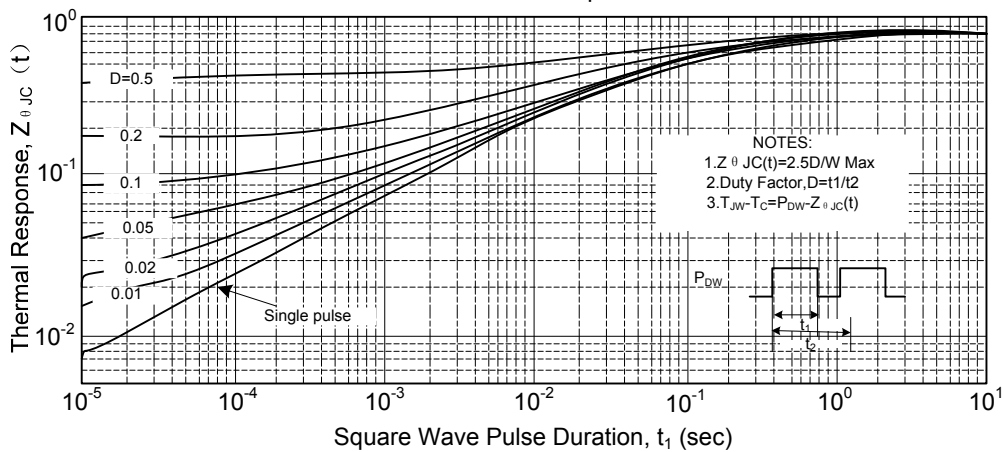

■ TO-220F-3L PACKAGE OUTLINE DIMENSIONS

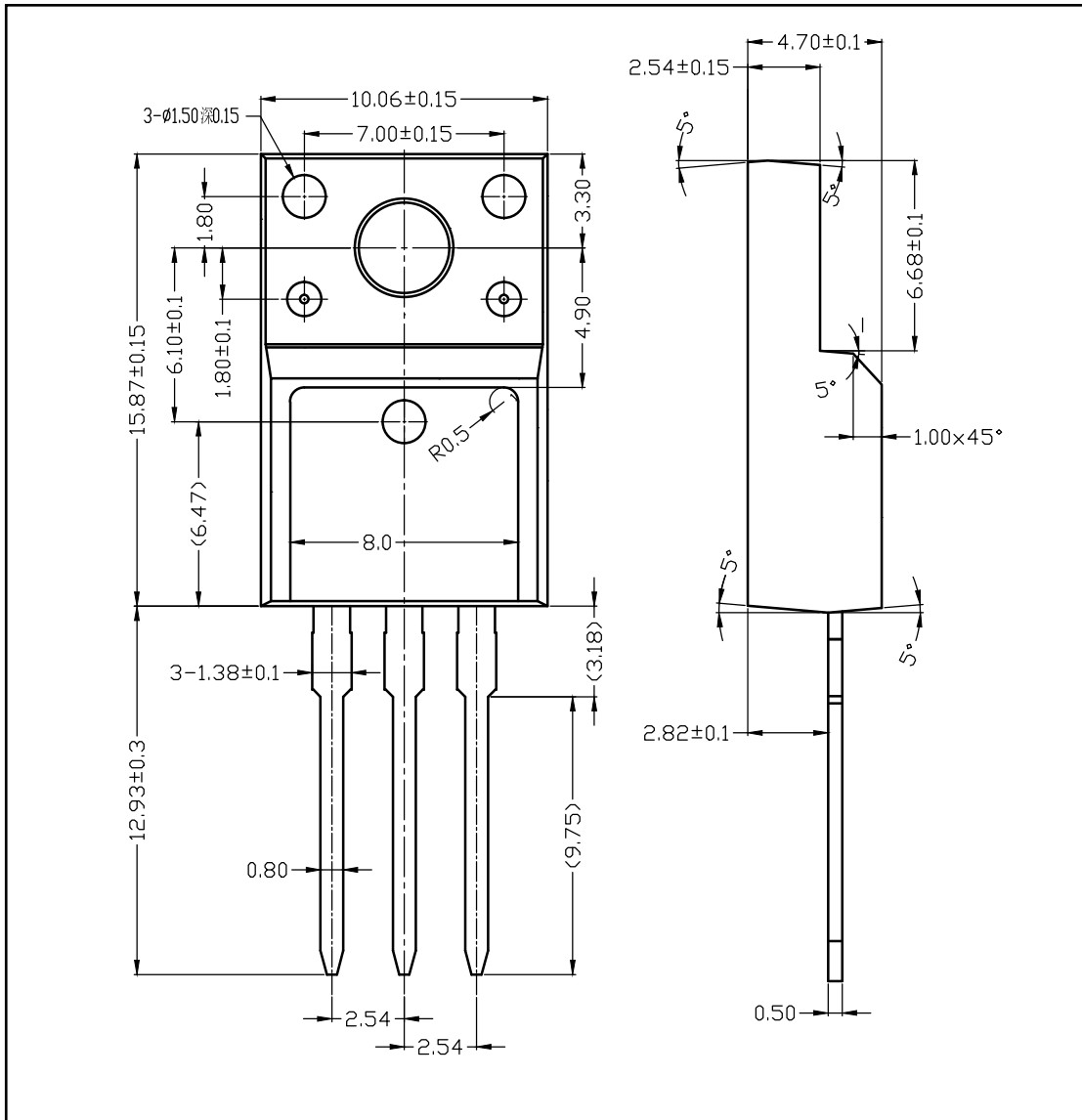

■ TO-220-3L PACKAGE OUTLINE DIMENSIONS

