

## General Description

The SESD3Z series is designed to protect voltage sensitive components from ESD and transient voltage events. Excellent clamping capability, low leakage, and fast response time, make these parts ideal for ESD protection on designs where board space is at a premium.

## Applications

- Cellular Phone Handsets and Accessories
- Microprocessor based equipment
- Personal Digital Assistants(PDA'S)
- Notebooks, Desktops, and Servers
- Portable Instrumentation
- Pagers Peripherals
- AEC- Q101 qualified

## Features

- Small Body Outline Dimensions
- 350 Watts peak pulse power ( $t_p = 8/20\mu s$ )
- Transient protection for data lines to
- Small package for use in portable electronics
- Suitable replacement for MLV's in ESD protection applications
- Protects one I/O or power line
- Low clamping voltage
- Low leakage current
- Solid-state silicon-avalanche technology

## Complies with the following standards IEC61000-4-2

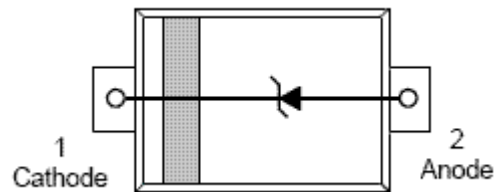
Level 4 15 kV (air discharge)

8 kV(contact discharge)

MIL STD 883E - Method 3015-7 Class 3

25 kV HBM (Human Body Model)

## Functional diagram

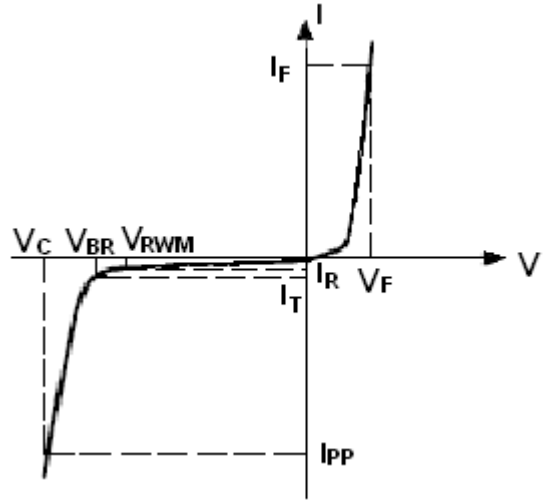


## Absolute Ratings (Tamb=25°C )

Symbol	Parameter	Value	Units
$P_{PK}$	Peak Pulse Power ( $t_p = 8/20\mu s$ )	350	W
$V_{ESD}$	ESD Voltage(HBM Waveform per IEC 61000-4-2)	8	kV
$T_L$	Maximum lead temperature for soldering during 10s	260	°C
$T_{STG}$	Storage Temperature Range	-55 to +150	°C
$T_J$	Maximum junction temperature	-55 to +125	°C
$I_{PP}$	Maximum Reverse Peak Pulse Current	24	A

## Electrical Parameter

Symbol	Parameter
$I_{PP}$	Maximum Reverse Peak Pulse Current
$V_C$	Clamping Voltage @ $I_{PP}$
$V_{RWM}$	Working Peak Reverse Voltage
$I_R$	Maximum Reverse Leakage Current @ $V_{RWM}$
$I_T$	Test Current
$V_{BR}$	Breakdown Voltage @ $I_T$
$I_F$	Forward Current
$V_F$	Forward Voltage @ $I_F$

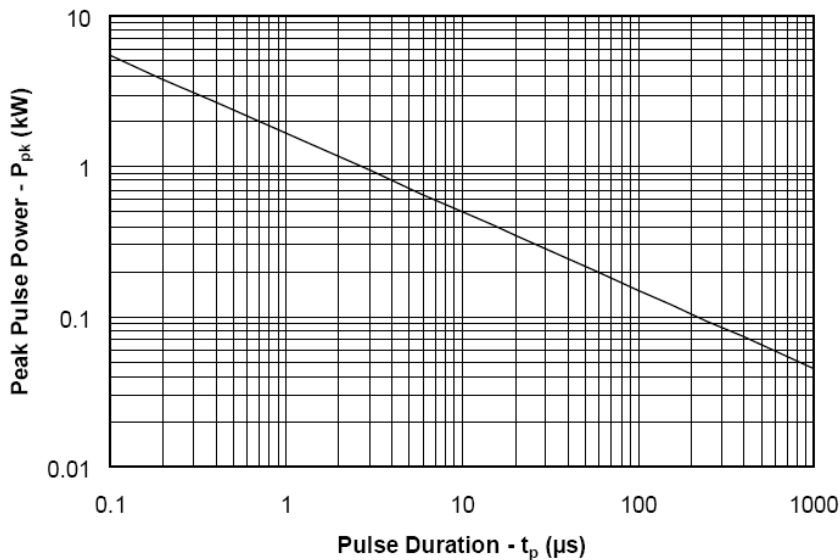


## Electrical Characteristics

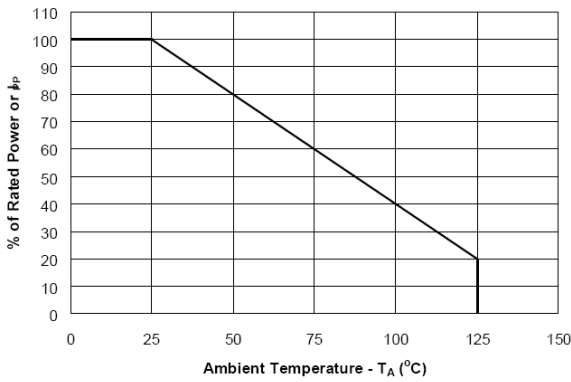
Ratings at 25°C ambient temperature unless otherwise specified.

Part Numbers	$V_{BR}$			$I_T$	$V_{RWM}$	$I_R$	$V_F$	$I_F$	$C$
	Min	Typ	Max				Max.		Typ. (Note1)
	V	V	V	mA	V	$\mu A$	V	mA	pF
ESD3Z3V3	5.0	6.0	7.0	1.0	3.3	1	1.25	200	35
ESD3Z5V	6.1	6.7	7.2	1.0	5.0	1	1.25	200	30
ESD3Z12V	13.3	14.0	14.7	1.0	12.0	1	1.25	200	25
ESD3Z16V	17.2	18.0	18.8	1.0	16.0	1	1.25	200	20

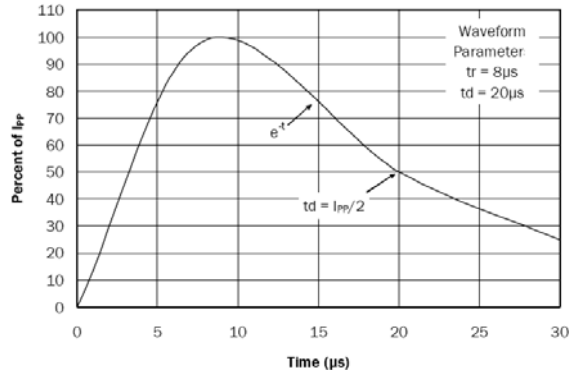
1. Capacitance is measured at  $f=1\text{MHz}$ ,  $V_R=0\text{V}$ ,  $T_A=25^\circ\text{C}$ .



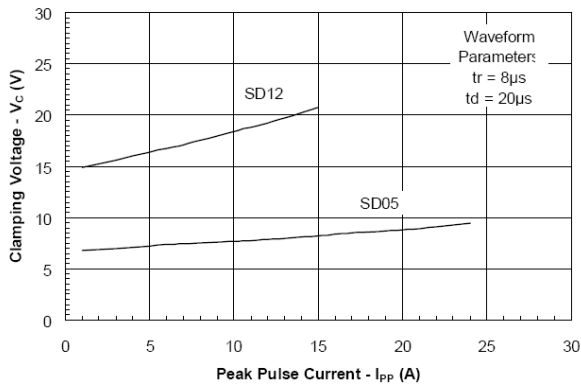
**Fig.1 Non-Repetitive Peak Pulse Power vs. Pulse Time**



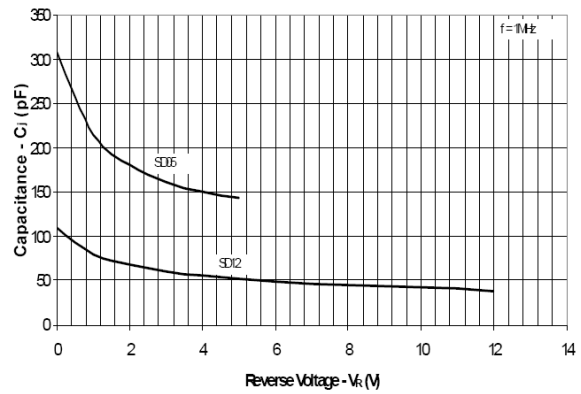
**Fig.2 Power Derating Curve**



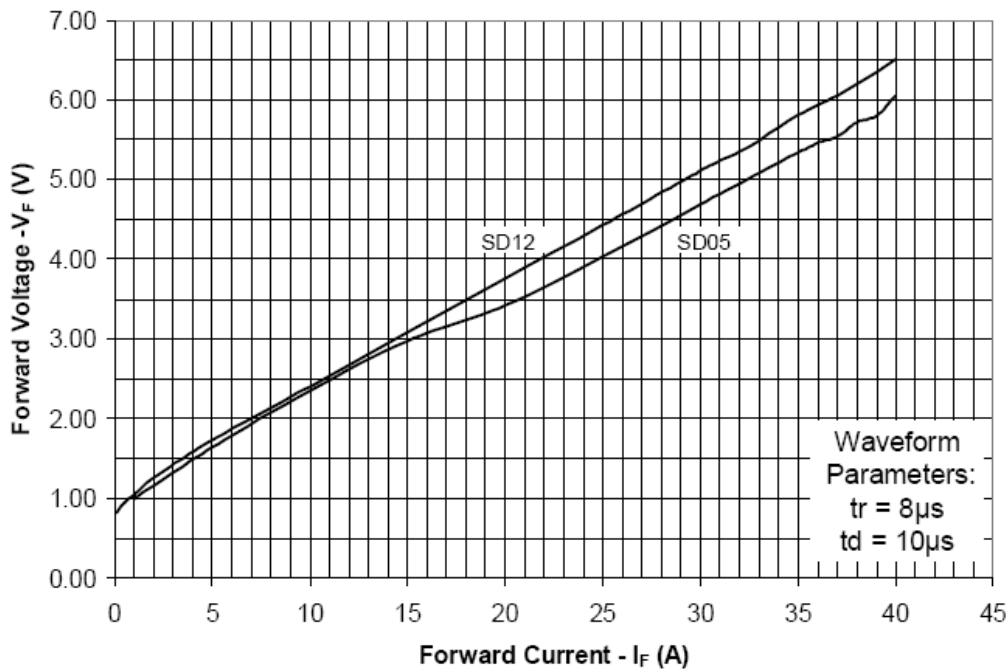
**Fig.3 Waveform**



**Fig.4 Clamping Voltage vs. Peak Pulse Current**

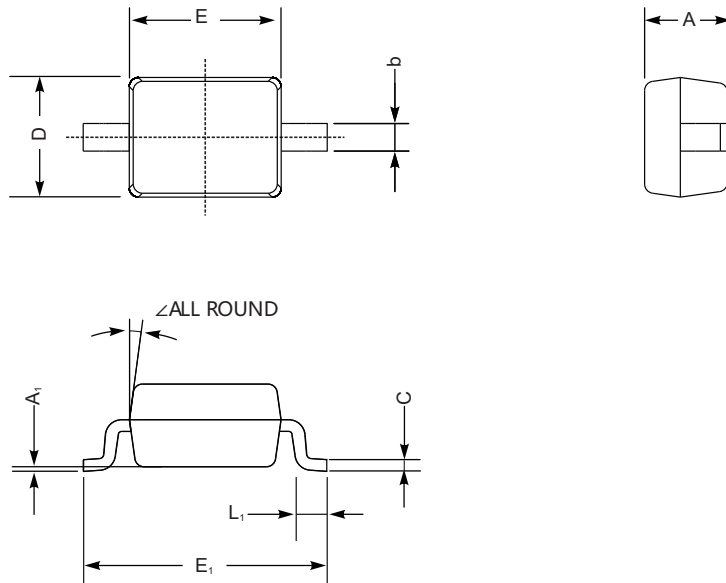


**Fig.5 Capacitance vs. Reverse Voltage**



**Fig.6 Forward Voltage vs. Forward Current**

## Package Outline



SOD-323 mechanical data

UNIT		A	C	D	E	E <sub>1</sub>	b	L <sub>1</sub>	A <sub>1</sub>	∠
mm	max	1.1	0.15	1.4	1.8	2.75	0.4	0.45	0.2	9°
	min	0.8	0.08	1.2	1.4	2.55	0.25	0.2	—	
mil	max	43	5.9	55	70	108	16	16	8	
	min	32	3.1	47	63	100	9.8	7.9	—	

## Ordering Information

Device	Package	Shipping
ESD3Z3V3 — ESD3Z16V	SOD-323	3000PCS/Reel&Tape